

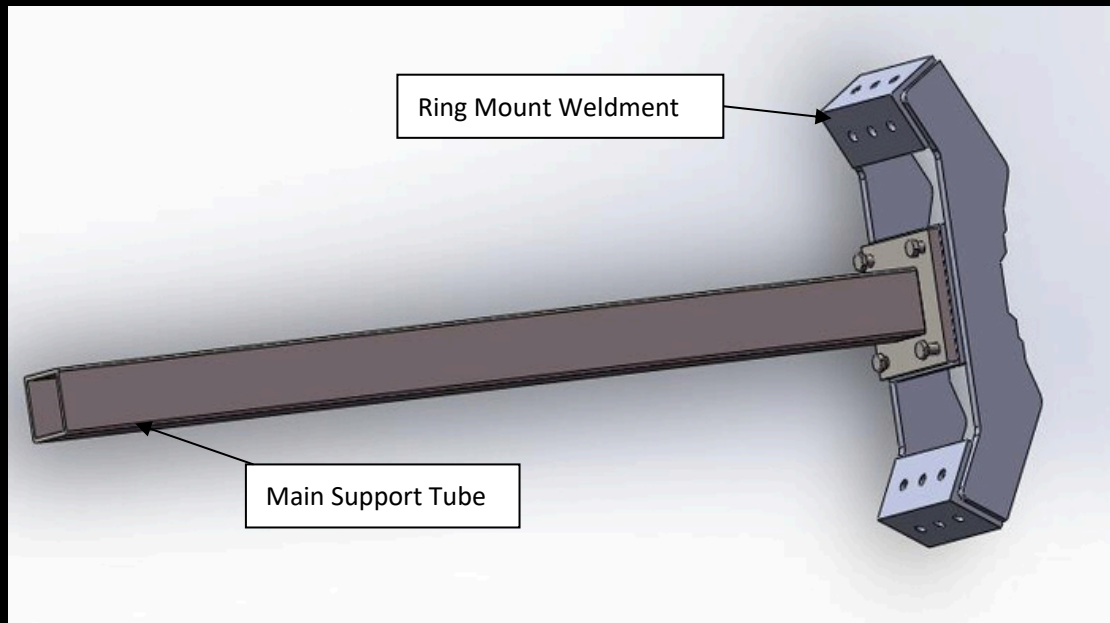

Low Profile  
Platform Installation  
Instructions

[www.amborstructures.com](http://www.amborstructures.com)



Step 1: Connect Main support tube and Ring mount weldment with M16x70x40 bolts one by one.

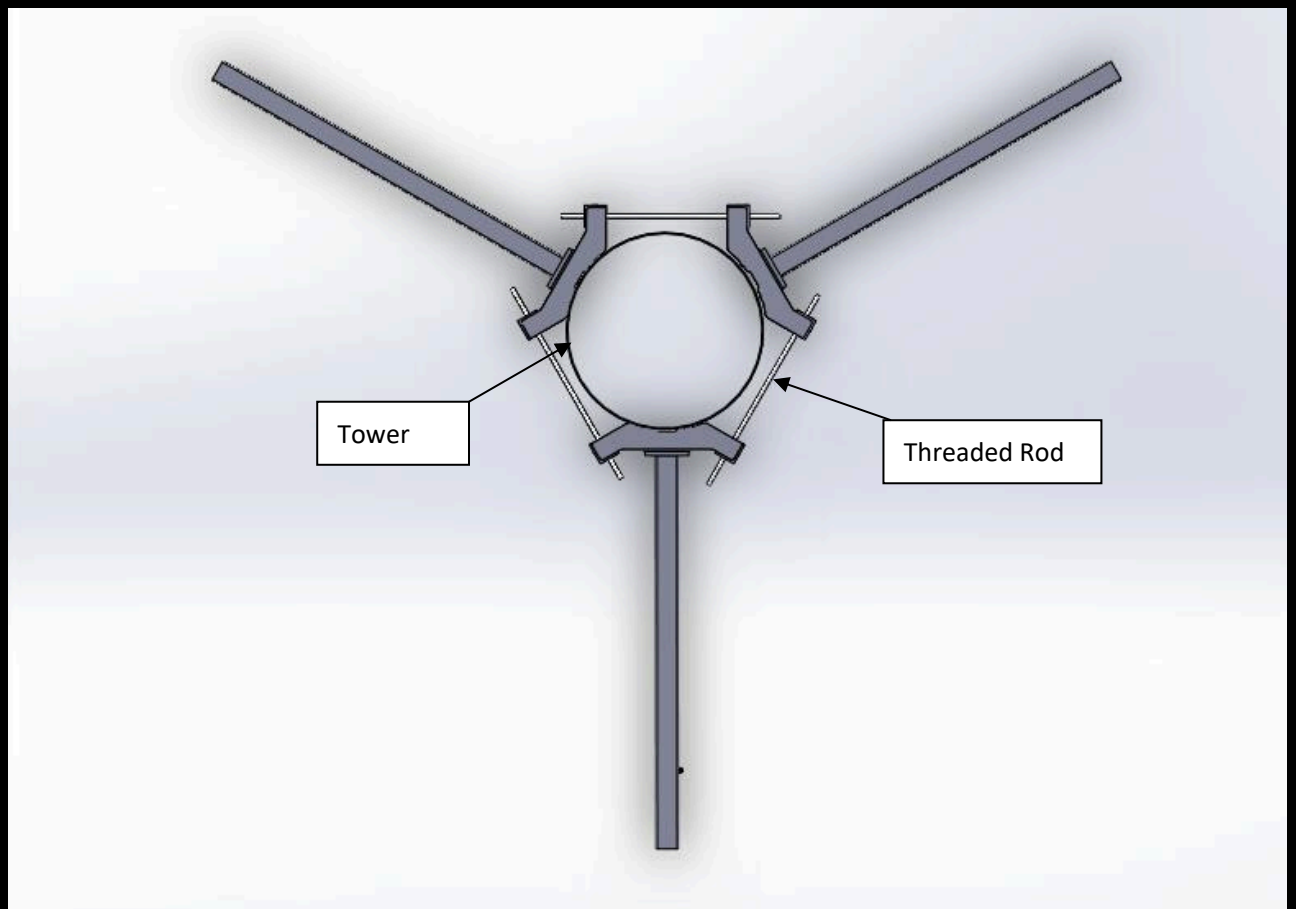

Step 2: Clamp these three Ring Mount Weldment to tower with Threaded Rod

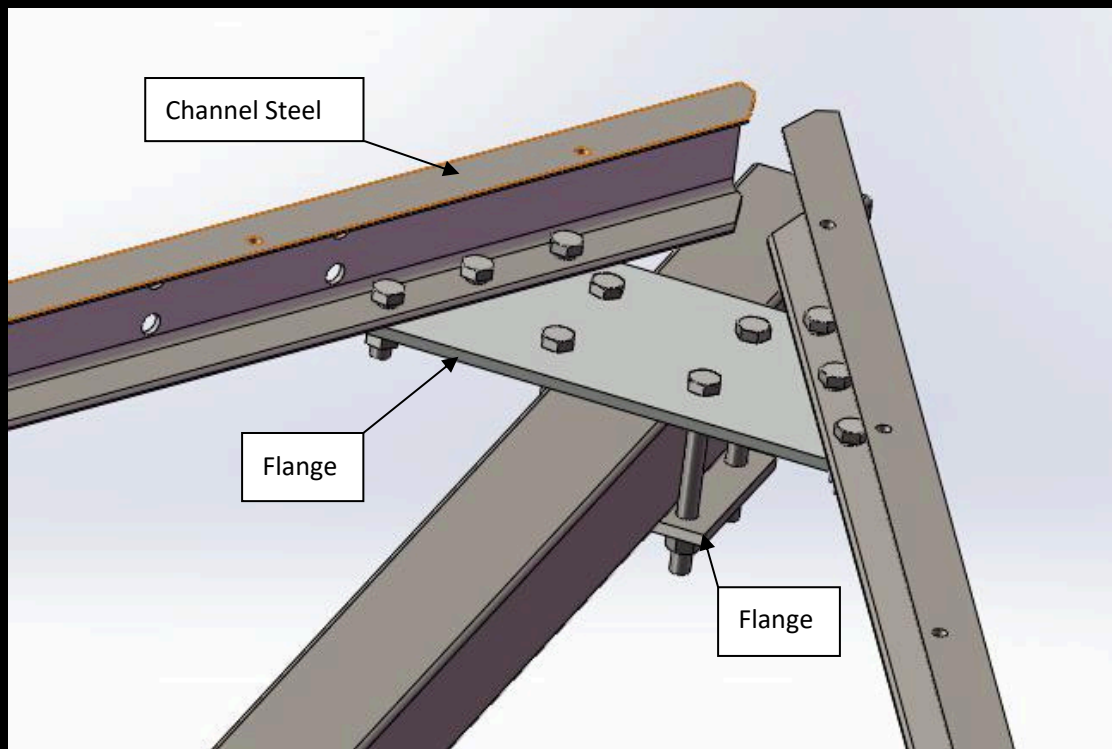
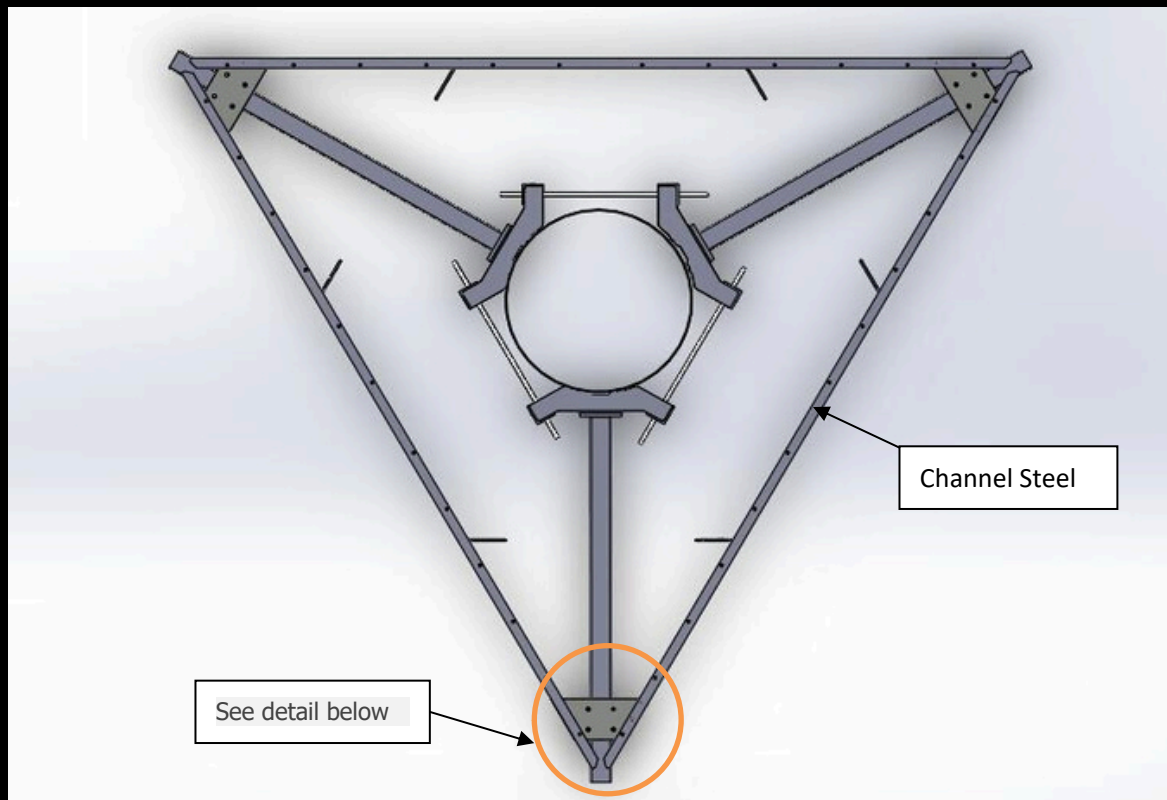

Step 3: Connect Flange 1 Flange 2 and Channel Steel with M16x165x45 and also M16x50 bolts.

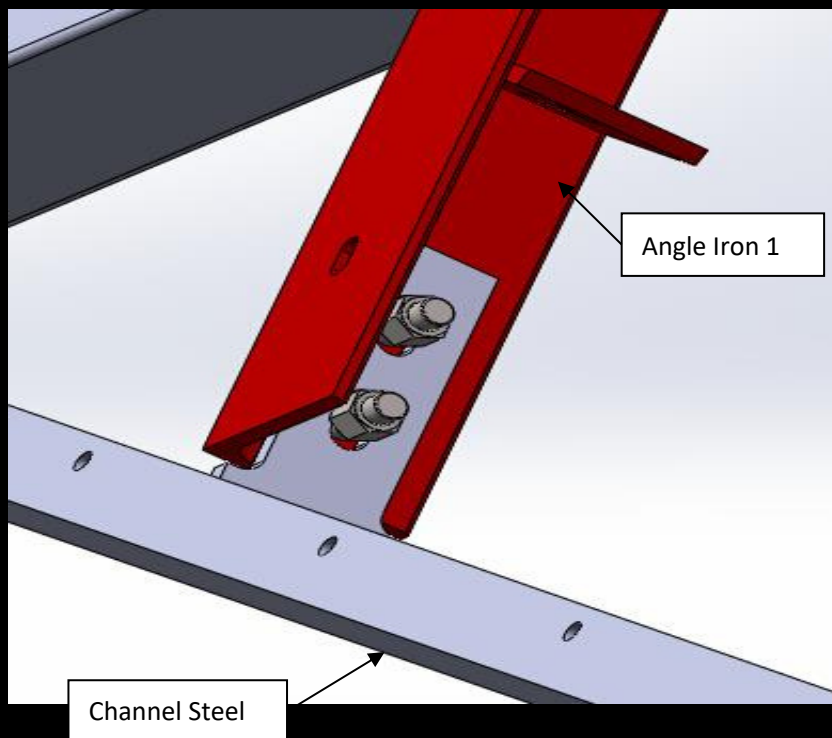
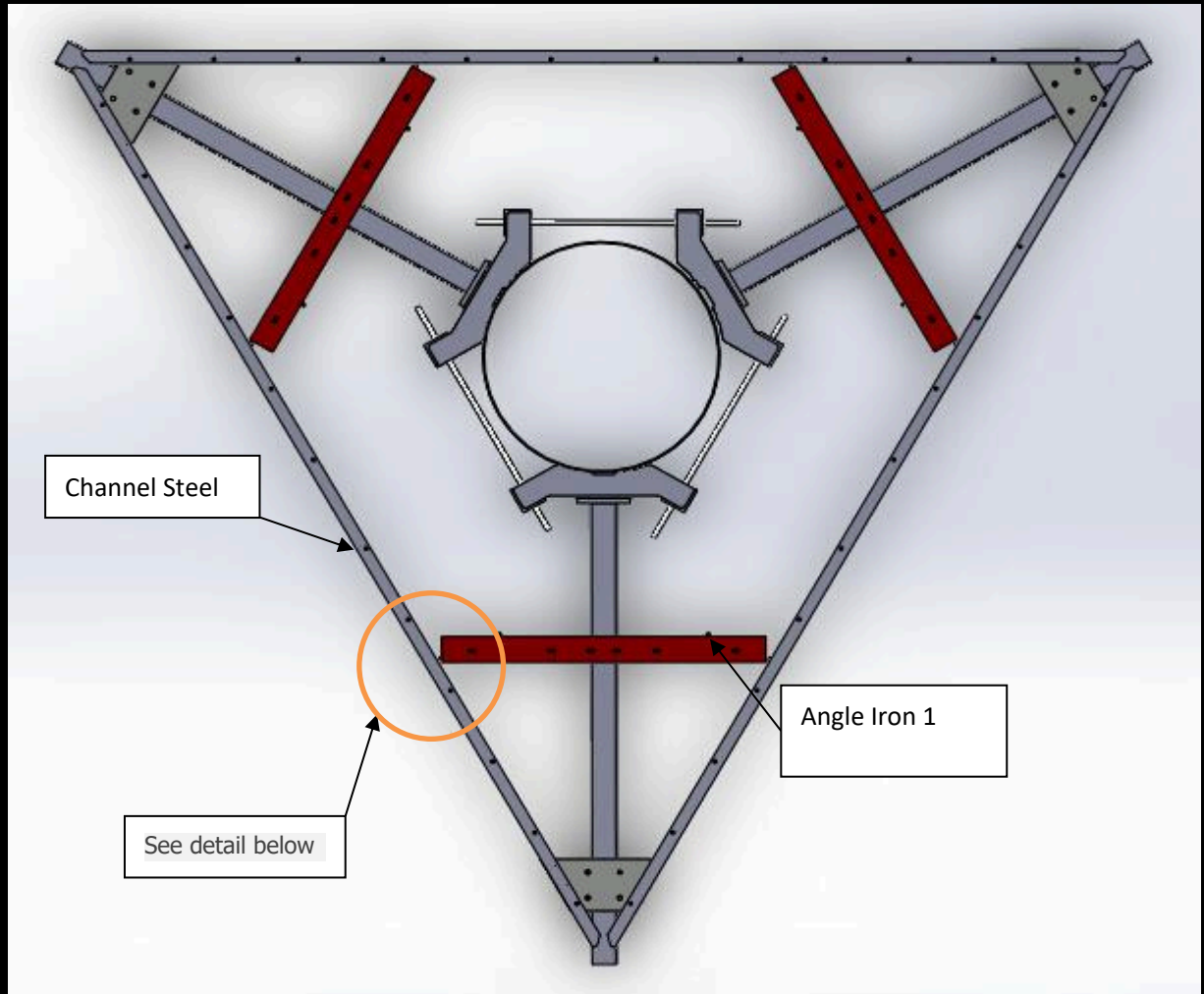

Step 4: Connect Channel Steel and Angle Iron 1 with M16 x50 bolts.

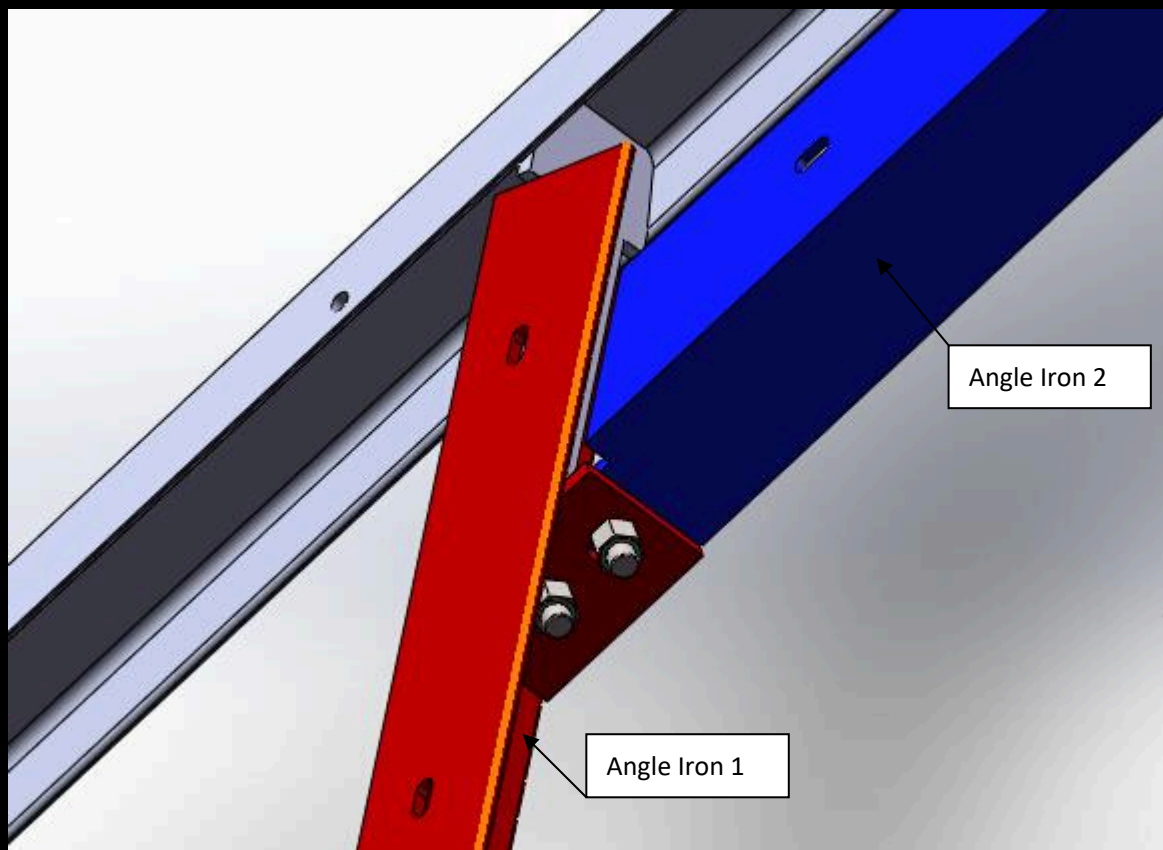
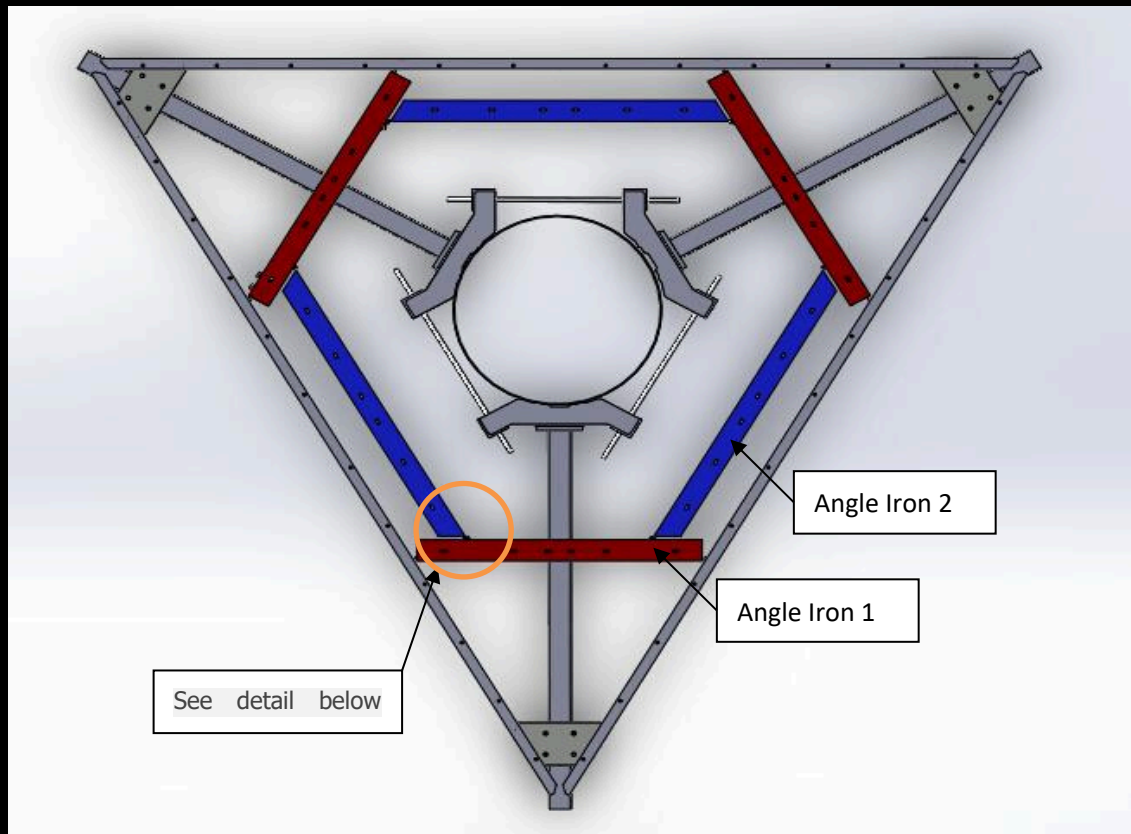

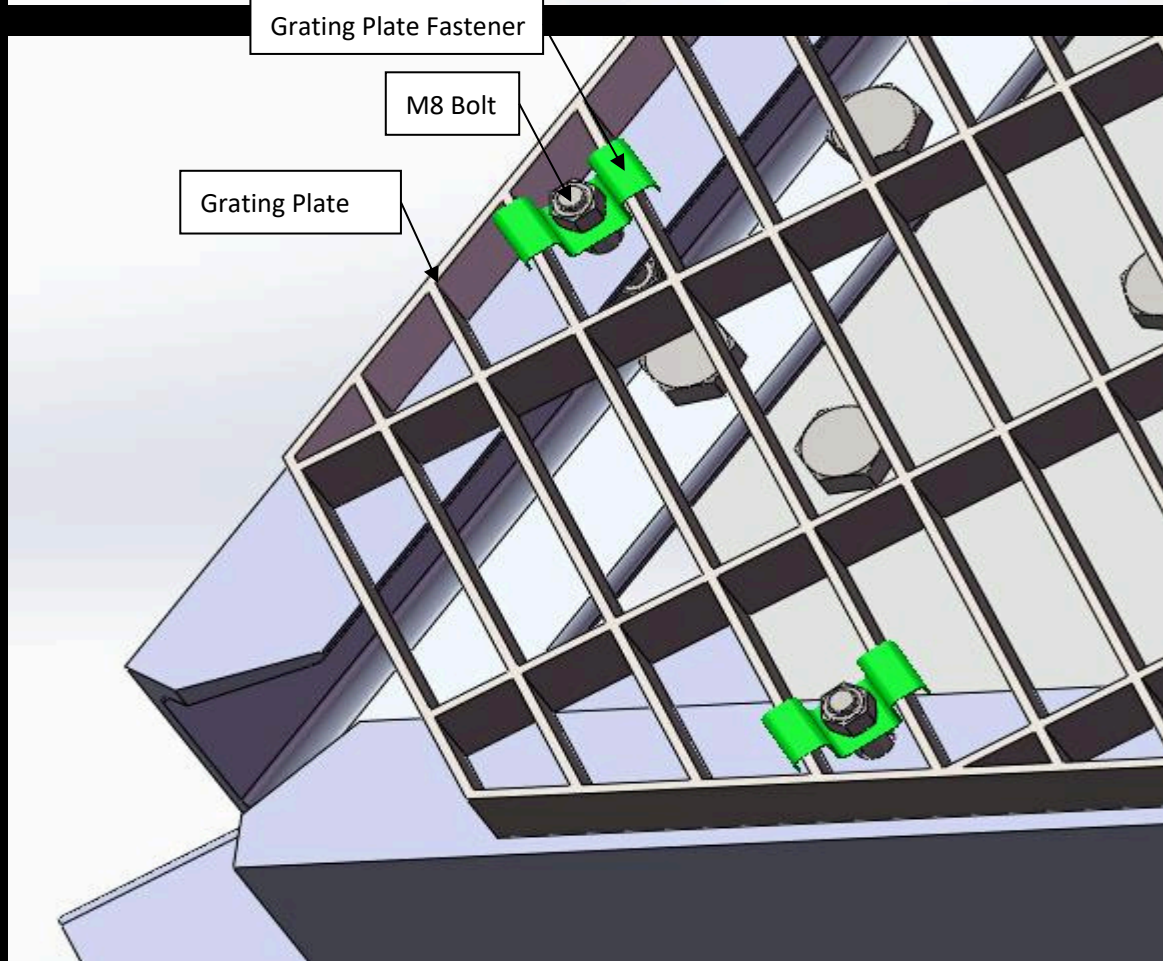
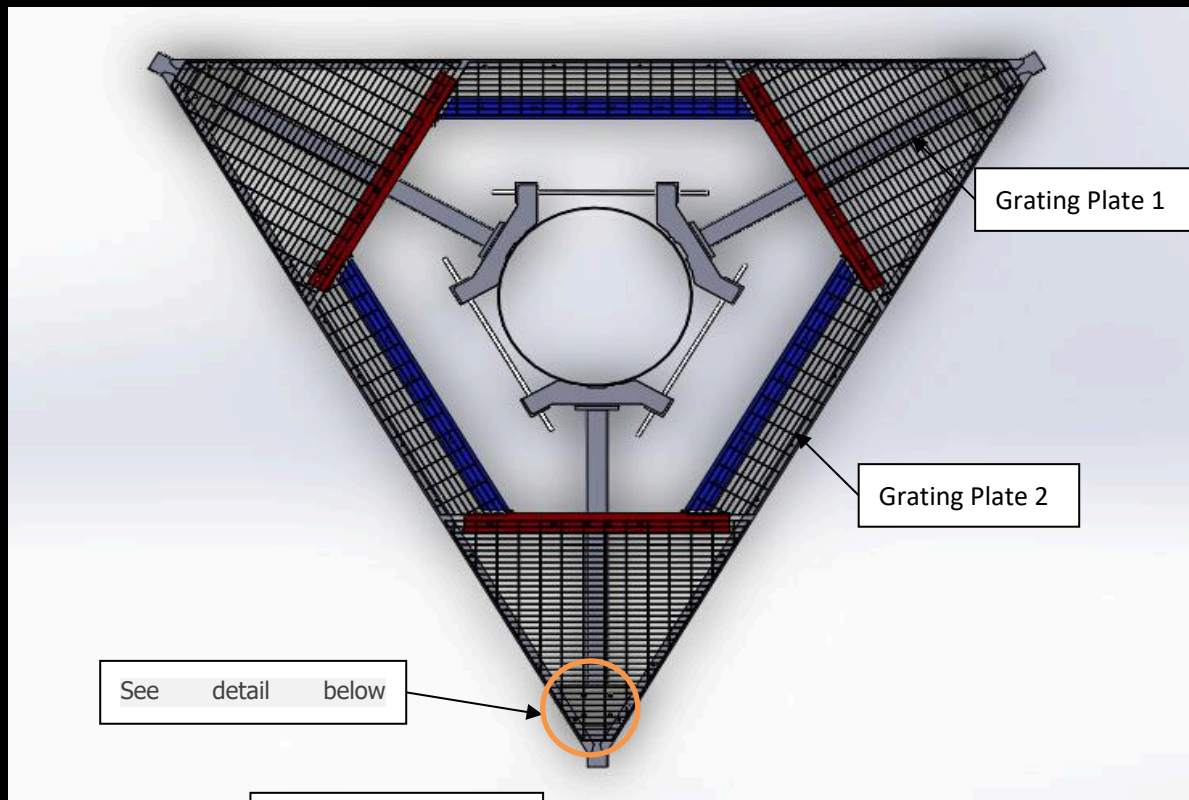

Step 6: Fasten Grating Plate on Angle Iron and Channel Steel with Grating Plate Fastener. Fasten all grating plate fastener is not necessary, around 3 fastener on each side of the grating plate will be enough and it's OK if there is no fasteners on one side of the grating plate. One of the three grating plate 2 cannot be installed on the platform when we need to have more space for climbing through the platform.

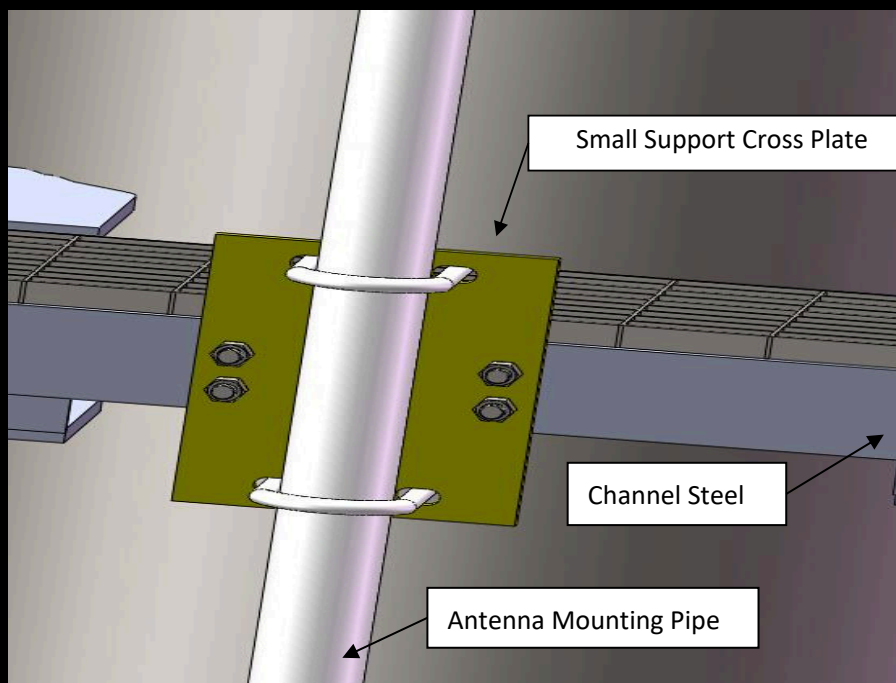
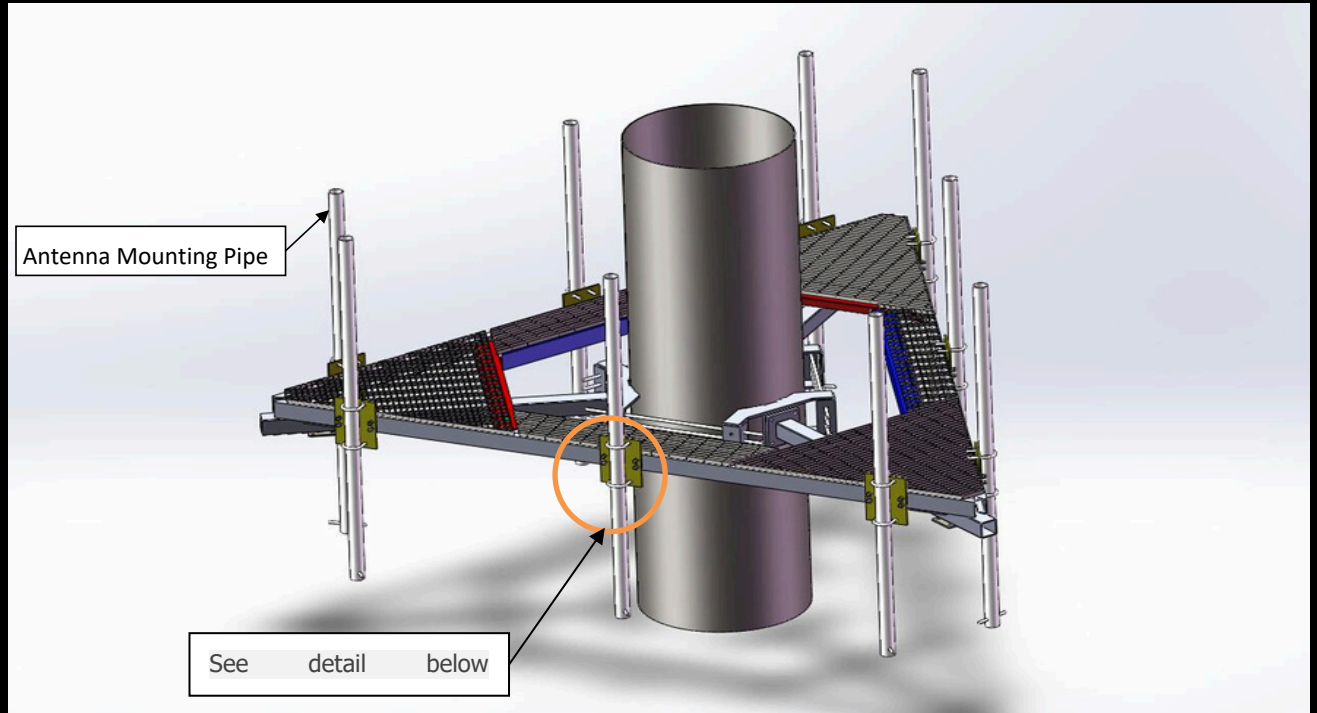

Step 7: Connect Antenna Mounting Pipe and Small Support Cross Plate with U-bolts, they are fixed on the Channel Steel with M16x50 bolts.

Make sure all bolts are tightened after installation.