



Motorized Tower Raising System Manual



Introduction and Safety Guidelines

Important!

- Read through the manual in its entirety prior to assembly and installation of the motorized tower raising system.
- **WARNING:** Improper use may cause property damage, serious injury or death; therefore, it is highly recommended that trained professionals are installing the towers and operating the raising/lowering system.

Safety

- Motorized Tower Raising Systems should be operated by personnel with proper training or knowledge.
- All planning should take place prior to installation to determine the required clearance and ensure proper space for raising and lowering the tower.
- The work area should be kept clean and free from trip hazards.
- Products should be inspected for damage prior to use. If any damage is noted, parts must be replaced or repaired immediately, per manufacturer's recommendation.
- When construction or erection of free-standing objects is planned, it must be in compliance with local ordinances and local design specifications (i.e. wind speed requirements)
- Tower grounding must follow local ordinances. If no local ordinance is given, you may refer to the Ambor Pole Grounding Manual.
- During tower installation, all operators must wear head protection and take adequate safety precaution. Never leave the motorized screw jack unattended while in operation.
- **NEVER** stand or walk beneath a tower in the middle of the installation. Operators must remain a minimum of two meters from the pole when operating the equipment.
- During installation, the operator must take note of any unusual sounds, vibrations or unnatural system behavior during operation. If anything is observed, operation should **STOP IMMEDIATELY** and the system must be assessed. Contact Ambor for assistance with any pole-related concerns. Your seller/manufacturer can be contacted for assistance with concerns about the foundation, hydraulic RAM cylinders, or other installed components.
- Installation and/or assembly during severe weather conditions must be avoided, especially electrical storm activity (lightning).
- Maximum allowable wind speed during installation or maintenance is 17m/s (38mph).
- **SAFETY FIRST!** Caution and common sense must be used when installing/using this product.

Introduction and Safety Guidelines

Maintenance

- Check the lifting screw for damage and debris prior to each use and make sure it is removed prior to using the system. If there are burrs on the thread surface, remove them with a hand file only. Ambor Structures will provide a dust cover for additional protection.

- Replace damaged dust cover as needed. Contact Ambor Structures, Inc, for replacements.

- Check for wear and damage of the complete raising/lowering system including the tower and foundation connection brackets prior to use.

- Lubricate the jack and lifting screw while operating in normal service conditions. Worm gear grease port is located on the jack housing. Lifting screw threads can be lubricated by disconnecting the dust cover clamp and exposing the lifting screw threads. Recommended Grease: OMEGA 77, produced by MAGNA Industrial Co, LTD. Mobile Mobilux EP# 1 Shell Aeroshell #22

- Lubricate the Motorized Screw Jack every year or every 15 running cycles. Lubrication may be required more frequently if the system is used in more extreme operating conditions.

- Every 100 running cycles or every 5 years (whichever comes first) the Motorized Screw Jack must be disassembled and checked for damage. One running cycle equals one time raising + one time lowering.

Bill of Materials: Motorized Raising System - 35T Long

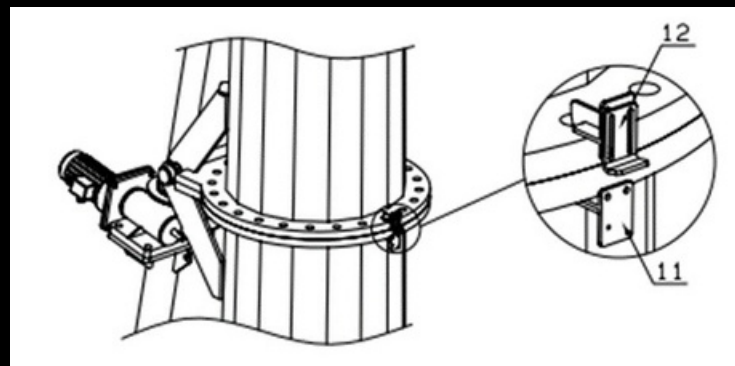
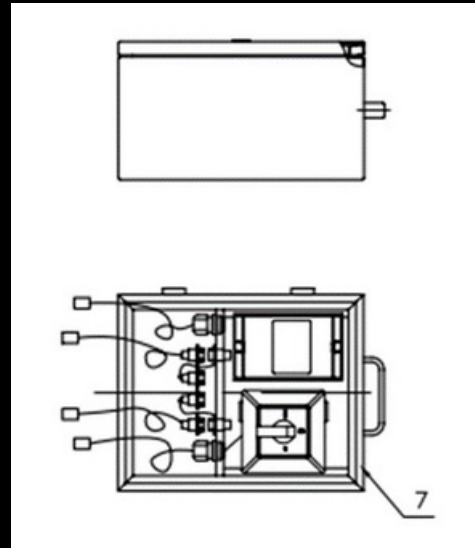
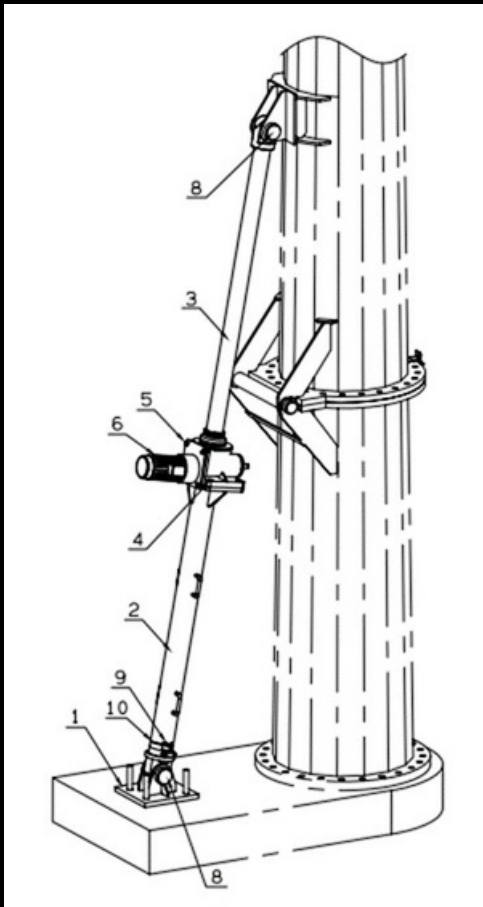

No.	Part No.	Description - 35T Long	Unit Weight	Qty
1	C508494	Screw Jack Support Base	46	1
2	C506083	35T Long Screw Jack Support	84	1
3	C508266	SWLD 35 M-1 A-IV 1840 F	220	1
4	C905194	Bolt Set M30x120x60 1N2W	/	4
5	C905191	Bolt set M16x50 1N2W	/	4
6		Motor	45	1
7		Controller	7.6	1
8	C753575	Pivot Axis	5	2
9	C507646	Limit Connecting Plate	0.3	1
10	C753009	Hose Clamp	/	1
11	C507644	Limit Bracket	0.3	2
12	C752876	Limit Plate	0.2	1
	C900441	Bolt M6x50	/	4
	C900101	Nut M6	/	2
	C900131	Washer 6	/	2
	C931747	Stop Pin Ø8x112	/	2
	FQT000094	Torque Wrench	/	1
	FQT000095	12.5mm Linch Sleeve	/	1

Bill of Materials: Motorized Raising System - 35T

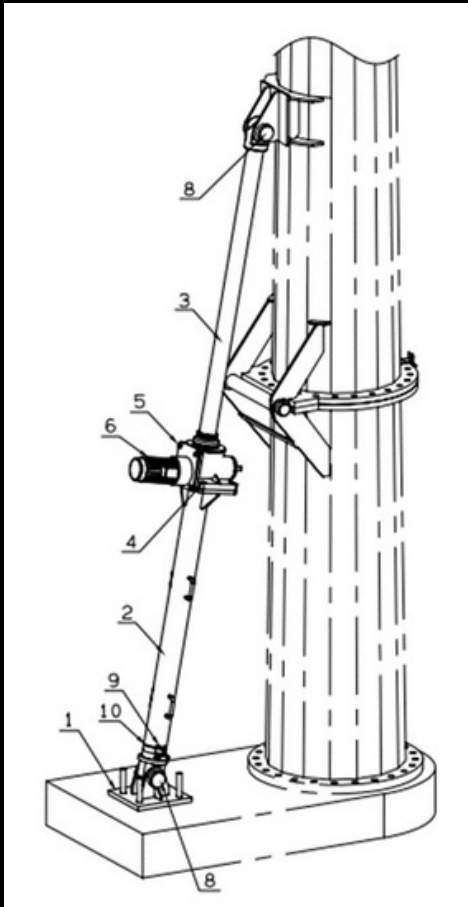

No.	Part No.	Description - 35T	Unit Weight	Qty
1	C508494	Screw Jack Support Base	46	1
2	C506083	35T Long Screw Jack Support	78	1
3	C508266	SWLD 35 M-1 A-IV 1510 F	204	1
4	C905194	Bolt Set M30x120x60 1N2W	/	4
5	C905191	Bolt set M16x50 1N2W	/	4
6		Motor	45	1
7		Controller	7.6	1
8	C753575	Pivot Axis	5	2
9	C507646	Limit Connecting Plate	0.3	1
10	C753009	Hose Clamp	/	1
11	C507644	Limit Bracket	0.3	2
12	C752876	Limit Plate	0.2	1
	C900441	Bolt M6x50	/	4
	C900101	Nut M6	/	2
	C900131	Washer 6	/	2
	C931747	Stop Pin Ø8x112	/	2
	FQT000094	Torque Wrench	/	1
	FQT000095	12.5mm Linch Sleeve	/	1

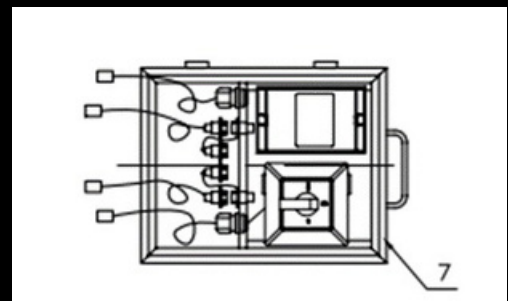
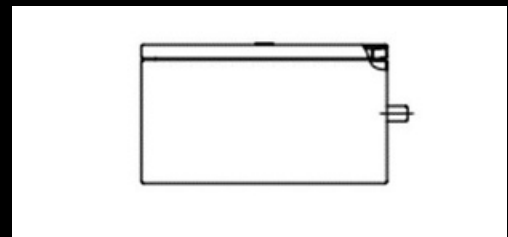
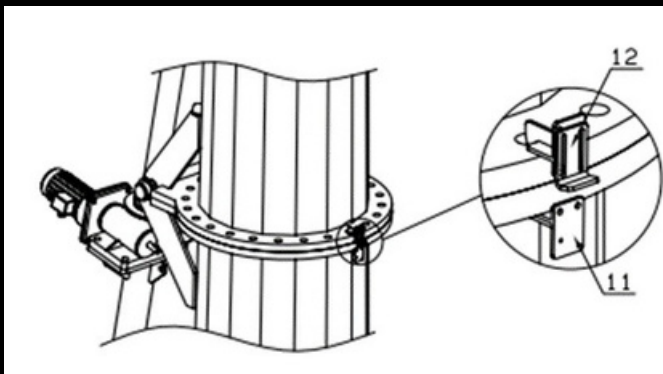

Bill of Materials: Motorized Raising System - 25T

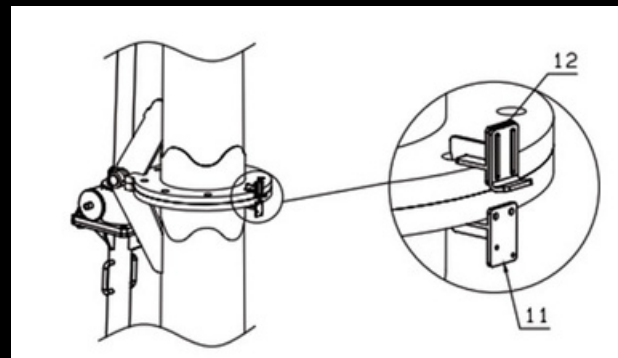
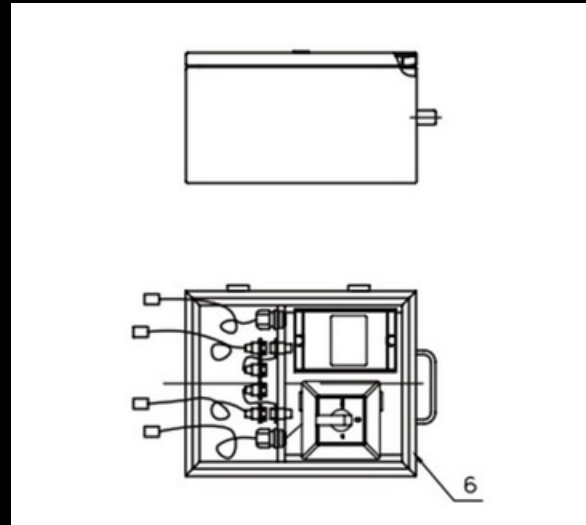
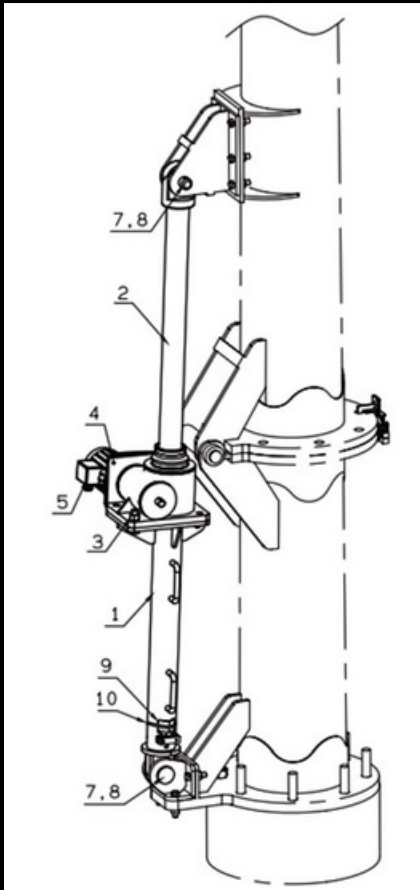

No.	Part No.	Description - 25T	Unit Weight	Qty
1	C507641	25T Screw Jack Support	36	1
2	FQT000135	SWLD 25 M-1 A-IV 960 F	138	1
3	C905025	Bolt Set M24x85x55 1N1W1SW	/	4
4	C905007	Bolt Set M12x40 1N1W1SW	/	4
5		Motor	20	1
6		Controller	7.6	1
7	C731843	Pivot Axis	2.1	2
8	C931923	Stop Pin $\varnothing 8 \times 100$	/	2
9	C507646	Limit Connection Plate	0.3	1
10	C753009	Hose Clamp	/	1
11	C507644	Limit Bracket	0.3	2
12	C752876	Limit Plate	0.2	1
	C900441	Bolt M6x50	/	4
	C900101	Nut M6	/	2
	C900131	Washer 6	/	2
	FQT000094	Torque Wrench	/	1
	FQT000095	12.5mm 1 inch Sleeve	/	1

Bill of Materials: Motorized Raising System - 20T

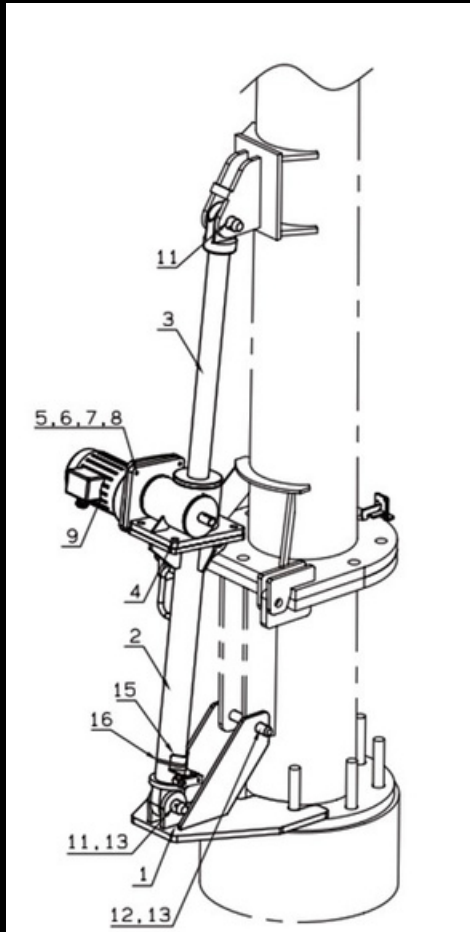

No.	Part No.	Description - 20T	Unit Weight	Qty
1	C503362	Boom Connection Plate	43	1
2	C504025	15T Screw Jack Support	15	1
3	C508873	SWLD 15 M-1 A-IV 580 F	41	1
4	C905014	Bolt Set M16x60x35 1N1W1SW	/	4
5	C900481	Bolt M10x35	/	4
6	C900483	Nut M10	/	4
7	C900133	Washer 10	/	4
8	C900161	Spring Washer 10	/	4
9		Motor	12	1
10		Controller	7.6	1
11	C721073	Pivot Axis 2	1.2	2
12	C721072	Pivot Axis 1	1.2	1
13	C503366	Control Crank	2	1
14	C507646	Limit Connecting Plate	0.3	1
15	C753009	Hose Clamp	/	1
16	C507644	Limit Bracket	0.3	2
17	C752876	Limit Plate	0.2	1
	C900441	Bolt M6x50	/	4
	C900101	Nut M6	/	2
	C900131	Washer 6	/	2
	C931282	Stop Pin $\varnothing 6.3 \times 56$	/	3

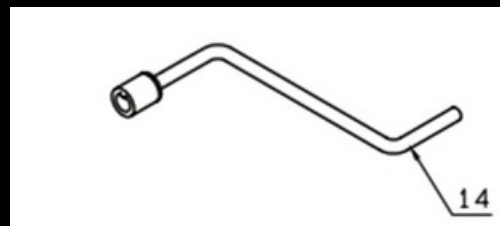
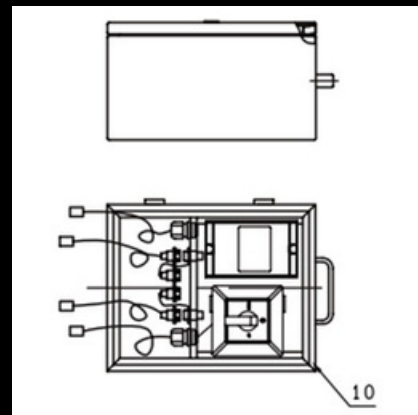
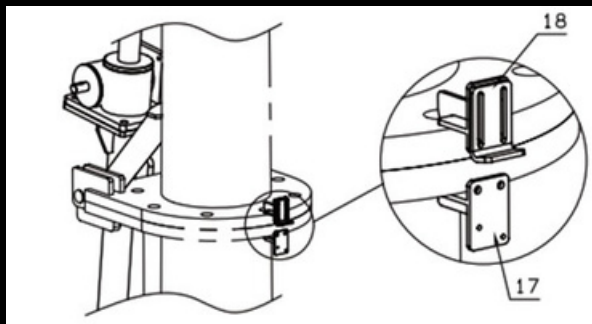

Bill of Materials: Motorized Raising System - 15T

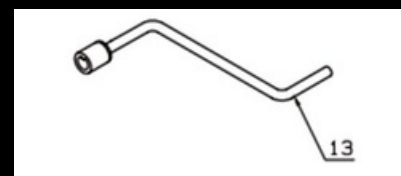
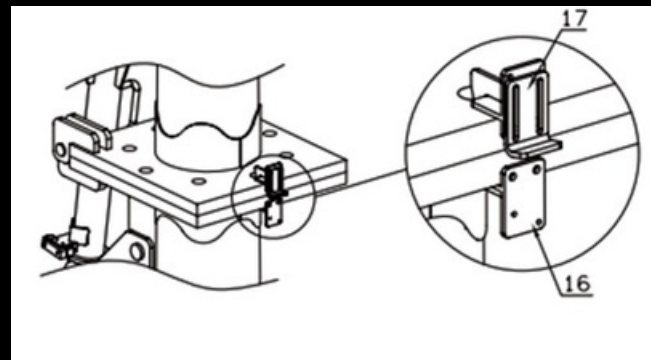
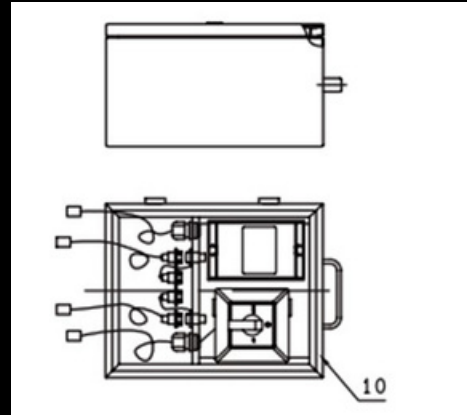
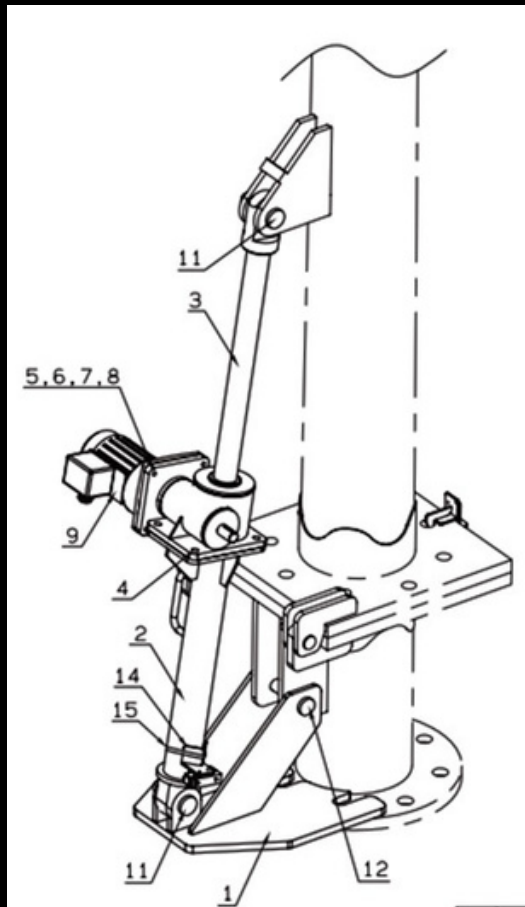

No.	Part No.	Description - 15T	Unit Weight	Qty
1	C503362	Boom Connection Plate	43	1
2	C504025	15T Screw Jack Support	15	1
3	C508873	SWLD 15 M-1 A-IV 580 F	41	1
4	C905014	Bolt Set M16x60x35 1N1W1SW	/	4
5	C900481	Bolt M10x35	/	4
6	C900483	Nut M10	/	4
7	C900133	Washer 10	/	4
8	C900161	Spring Washer 10	/	4
9		Motor	12	1
10		Controller	7.6	1
11	C721073	Pivot Axis 2	1.2	2
12	C721072	Pivot Axis 1	1.2	1
13	C503366	Control Crank	2	1
14	C507646	Limit Connecting Plate	0.3	1
15	C753009	Hose Clamp	/	1
16	C507644	Limit Bracket	0.3	2
17	C752876	Limit Plate	0.2	1
	C900441	Bolt M6x50	/	4
	C900101	Nut M6	/	2
	C900131	Washer 6	/	2
	C931282	Stop Pin Ø6.3x56	/	3

Prior to System Assembly & Operation

- Ensure that all bolts between the connecting plates have been removed prior to lowering the pole.
- Check the pivot axes to make sure they are correctly fixed and secured in the hinge.
- Remove anything unrelated to the motorized device and pole shaft from the area prior to operating the equipment.
- Check the connection between the wind turbine and tower to ensure that is completely installed before tower raising.
- Check the nuts on the anchor bolts to ensure they have been tightened to the recommended torque after the tower installation is complete.
- Remove the bolts installed in the connecting flange
- Please note: Motorized Screw Jack will bottom out in the supporting pedestal if left unattended. Ambor Structures is equipping the system with travel limiting switches but it should still be visually monitored during operation.

Motorized System Assembly

1. Check the Bill of Materials and make sure everything is present to begin assembly.
2. If you are assembling at the site, the first step will be to attach the Motorized System to the Support base. For larger motorized systems, you will need to use lifting equipment to help get the screw jack to the foundation. Always install the Motorized Screw Jack so that the support pedestal is linked to the foundation or Base Mounting Bracket as shown to the right.



- For the 35T and 35T Long systems, the support base will be separate from the tower. Attach the support base to the bolts installed in the foundation and then connect the support to the base using the Pivot Axis Pin and Stop Pin.
- The 25T system connects to a bracket that is part of the baseplate of the tower. Similar to the larger system, you will need to attach the support to the base bracket using the Pivot Axis Pin and Stop Pin.
- The 15T and 20T system connect to the bottom connection plate that is bolted and braced by the anchor bolts/nuts. When bolting down the base section of the tower, make sure you attach the bottom connection plate and secure it down with the M33 anchor nuts. Once that is in place you can secure the support to the base bracket with the Pivot Axis and Stop Pins.

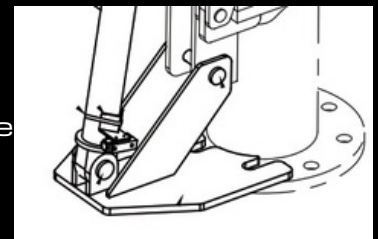
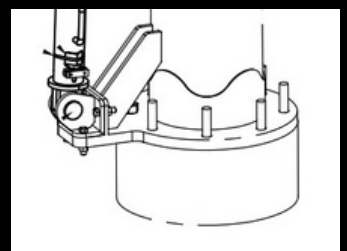

ORIENTATION of MOTOR/JACK – Motor and jack assemblies are oriented in one of two ways to the system.

- For larger systems, the motor is positioned away from and perpendicular to the tower hinge axis.
- For smaller systems, the motor is positioned parallel to the tower hinge axis.
- Note: Lifting screw should always be located close to the tower hinge axis, regardless of which side of the jack the motor is mounted on.

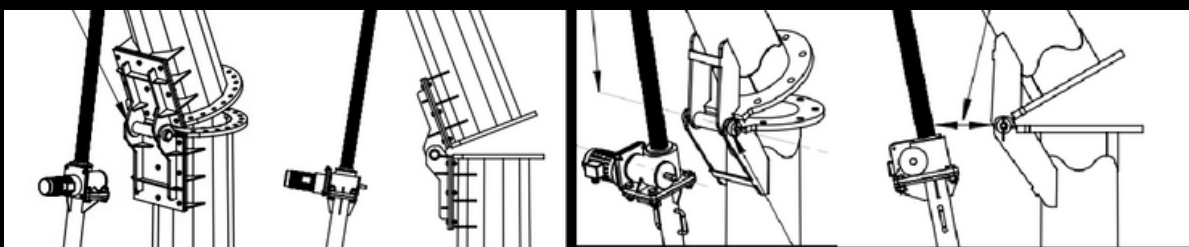

Motorized System Assembly cont.

Once the Support is in place, you can begin attaching the other components of the Motorized Raising System— Starting with the worm gear screw jack and lifting screw.

It is possible that the majority of the system will already be assembled in the crate upon arrival (see picture to the right—has worm screw and worm gear screw jack already assembled. If that is the case, skip to step #5.



- Using the bolt set specified in the BOM for your size Raising System, attach the Worm Gear Screw Jack to the Support. As shown to the right, make sure the screw jack is supported off the ground to avoid damaging the motor or threads on the lifting screw.



- Insert the lifting screw (or worm screw) into the top of the worm gear screw jack and begin to screw it in. It is
 - Insert a dowel into the link of the lifting screw and use it as a handle. Rotate the wooden rod manually to screw it in.
 - If this this has come already installed, it may have a dustcover over the screw jack for additional protection. Before screwing and unscrewing the worm screw, loosen the hose clamp on the dustcover and pull it off the lifting screw link. If this is not done, the dustcover may tear.

- Align the motor to the Worm Gear Screw Jack. Use the four bolt sets to fix the two together.



- You will need to slide the metal piece on the motor into the housing on the screw jack . If that does not align with the holes, you can twist to get them to align.

Installing Cut-Out Sensors

As a measure of safety precaution, Ambor is providing cut-out sensors to be installed with the motorized system. These cut-out sensors help to automatically shut off the motor once the tower is either fully raised or lowered. Although these limit switches are automatic, the system is not to be used without supervision from the operator. Failure of these limit switches could result in a broken equipment.

Worm Screw Sensor

1. Begin by assembling the pieces of the worm screw sensor. Attach the sensor to the metal bracket.
2. Your sensor may come with the stick attached. If not, attach the sensor stick at this time.
3. Insert the sensor stick into the opening at the base of the screw jack. Make sure the sensor stick is at least 12mm from the bottom edge of the opening.
4. Secure the sensor system in place by tightening the hose clamp around the angle steel
5. Attach the sensor cable to the motor control box

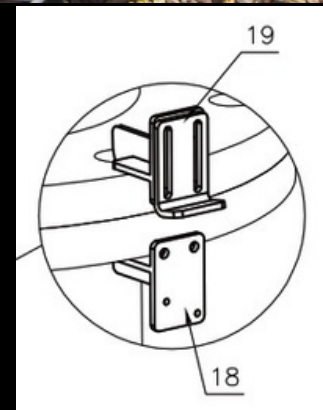

Tower Flange Sensor

1. The tower flange sensor will need to be installed prior to lowering the tower or before the tower is installed. It is important that this step be completed when the flange connection is together so you can adequately adjust the sensors to ensure they meet together.
2. The top and bottom mounting brackets will attach using the bolt holes in the flange connection. To lock into place, tighten the cup point set screws using an Allen wrench.
3. Install the sensor to the bottom mounting bracket and tighten the nuts.
4. Attach the stop piece or limit bracket to the top mounting bracket. You will need to adjust slightly so that it pushes down on the sensor. Tighten the lock nuts until snug tight.
5. Attach the sensor cable to the motor control box.



Motor Controller Assembly

Before connecting the motorized system to the tower, test the system to ensure it is operating properly. Follow the Motor and Controller Assembly instructions prior to attaching it to the tower.

The motorized system was designed for simple installation. The system consists of:

- A motor starter which can be used to manually shut off power to the rotary cam switch
- A rotary cam switch for with a forward (UP) rotation , reverse (DOWN) rotation and an OFF position

Motor controller Assembly

1. Using one of the white cables, attach the control box to the screw jack motor using the 5 prong Motor plug.

2. Using the black cable on the left hand side of the control box, connect to the main power source.

- Note: Each motor is built for specific voltage, Hz and jack size. Plug and voltage specifications will have been provided at the time of the order.

3. Sensors should already be attached to the box. If not, follow the instructions on installing cut-out sensors.

4. Turn ON the motor starter.

5. Test each sensor and switch individually to ensure everything is working properly.

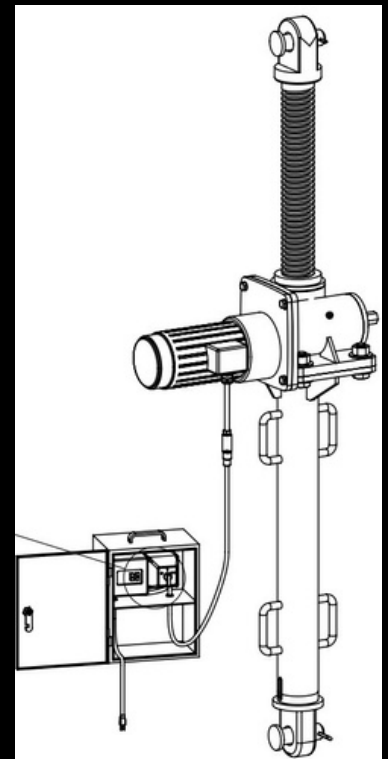

Raising the Tower

Before connecting the motorized system to the tower, check again to make sure that the dustcover boot is not attached to the worm screw link. It's best to raise and especially lower the screw jack with the dustcover unattached. It helps to prevent getting it caught in the threads and tearing.



1. Beginning with the screw jack resting in the downward position, lift up the screw jack so it is off the ground and pointed toward the connecting plates on the tower.

- Note: Heavier jacks will require additional support from lifting equipment.

2. Turn the cam switch on the motor control box to the up position. Once the worm screw has reached the tower, turn the cam switch to the off position and connect it to the connecting plate with the tower clevis pin.



3. Turn the cam switch back to the up position and continue raising the tower until it is in the full upright position. The tower flange cut-off sensor should automatically shut off the motor when it has reached that position.

Immediately

Make sure to turn the cam switch into the off position as well.

4. Insert the bolts around the flange connection and tighten the nuts to secure the tower.



Lowering the Tower

Before lowering the tower, check again to make sure that the dustcover boot is not attached to the worm screw link. It's best to lower the screw jack with the dustcover unattached. It helps to prevent getting it caught in the threads and tearing.

1. Beginning with the screw already attached to the tower, loosen all the nuts and bolts around the connection flange.

2. Once all of the bolts are removed, turn the cam switch to the DOWN position.

3. Do not leave the operating screw jack unattended while lowering.

4. Once the worm screw is completely housed by the support, the sensor stick will shut off the motor. Immediately Make sure to turn the cam switch into the off position as well. If you would like to stop lowering before the screw jack gets all the way down, you can manually turn the cam switch to the off position.

5. Support the tilted down tower at the preferred height for maintenance on equipment.

